

LANEFX BLIND SPOT EXPOSURE SYSTEM

2007



INSTALLATION GUIDE

installer friendly lay-flat booklet

IMPORTANT INFORMATION



Thank you for purchasing LaneFX. LaneFX is designed to be a 100% universal product that works in any vehicle equipped with power mirrors. LaneFX installation is best performed by an experienced mobile electronics installer.

Things to remember

- This Installation Guide and the enclosed LaneFX Owners Guide are for LaneFX Basic, Highway, Commuter and New Car Editions.
- You should never use your LaneFX's customization LCD screen while the vehicle is in motion. **LaneFX is disabled whenever the LCD is NOT in the normal run screen.**
- It's important to calibrate LaneFX's mirror return accuracy. **Improper mirror accuracy calibration may cause a mirror to lose its original position after repeated LaneFX (or ParkFX) iterations.**
- Never activate LaneFX in a vehicle with a partially/nearly-drained battery (approx. less than 3v). Doing so may cause irreversible damage to LaneFX.
- LaneFX is design only for 12v vehicles.
- This LaneFX package can be installed in left-hand drive as well as right-hand drive vehicles.

What you should expect in this installation

The installation procedure is made up of the following high-level steps:

1. Preparing the vehicle
2. Identifying the vehicle's wiring setup
3. Rerouting the side mirrors' control lines through LaneFX
4. Connecting all other components (LED's, buttons, turn signals and reverse light)
5. Programming LaneFX to learn the electrical configuration of the vehicle.
6. Calibrating the mirrors

At the end of installation you should also customize LaneFX to suit your driving style. Customization can be done using the system's LCD screen. Instructions on how to customize LaneFX are included in the accompanying Owners Guide.

LANEFX PACKAGE CONTENTS



At Drivaware, we are committed to complete and quality hardware as well as to your total satisfaction. Please check the contents of your LaneFX package before starting installation work. In the unlikely event that your LaneFX package is incomplete or contains a defective component, please let us know at (866) 4-LANEFX or at support@LaneFX.com

What's in the box

The following is the hardware content of each LaneFX system:

- (1) LaneFX main unit
- (1) Left wiring harness (14-pins)
- (1) Right wiring harness (10-pins)
- (2) "Mirror-in-motion" LEDs
- (2) Activation Buttons
- (1) Owners Guide
- (1) Installation Guide



What's not in the box

The following items are not supplied with the LaneFX hardware but you will likely need them during installation:

- Additional wires – 18-gauge; unique colors highly recommended
- Connectors – Use any professional strength wire connection. Soldering is best. Twist connections and simple electrical tape are least reliable and not recommended
- Laser pointer (optional) for mirror calibration
- Conventional installation shop supplies – zip ties, interior panel removal tools, etc...



1. Know what features you have in your LaneFX Edition

Regardless of which features your LaneFX system is equipped with, we highly recommend installing LaneFX with all of the connections (like turn signal and reverse links). LaneFX is upgradeable using the web. So a complete initial installation allows you to unlock optional features you do not have at any time in the future and without having to install any additional hardware or connections.

2. Choose the location of the LaneFX unit, LEDs and activation buttons

Choose a location for the **main LaneFX unit** so that it is a) concealed and b) easily reachable so that the driver can make modifications and see their impact on the vehicle's side mirrors without moving. The most popular anchor positions for the LaneFX main unit is in the center console or in the glove compartment.

Choose a location for the **LaneFX activation buttons** such that a) they are installed side-by-side b) they are easily reachable by the driver's hand without any obstruction. The most popular position for LaneFX activation buttons is in the area of power window controls on the left arm rest of most vehicles. Choose a location for the **LaneFX "Mirror-in-Motion" LED's** such that a) they are installed side-by-side b) they are readily visible to the driver without any obstruction. The most popular positions for installing LaneFX LEDs is on the driver side arm rest, front center console / dash, next to or below instrument cluster.

STEP 0

PREPARE THE VEHICLE



TIP

Do not remove the passenger side interior door panel right away. You may not need to remove it at all during this installation. Wait until Step 2 when you have to identify all of the power mirrors' control lines. At that point, you can check to see if you can make all passenger-side power mirror wiring connections directly from the switch in driver-side door.

1. Remove the **driver side inside door panel**, but do not disconnect the Molex harness that connects electrical components of the door to their corresponding controls on the inside panel of the door. This installation will be focused on the wiring harness that is connected to the power mirror adjustment switch.
2. Remove any additional panels required to run wires and to place the LaneFX unit and its components (LEDs & activation buttons) in desired location.
3. Identify **location and wire color** of the following:
 - a. accessory (not constant) +12v power source (the power source that is on when ignition is number II position)
 - b. Vehicle ground
 - c. Reverse light signal
 - d. Left turn signal
 - e. Right turn signal
4. Above wire codes are available from many sources:
 - a. Professional aftermarket wiring databases. We recommend Directwire™.
 - b. Alternatively, most local aftermarket retailers provide this information.
 - c. Or, you could contact the vehicle's authorized dealer and request these wire color codes.

STEP 1

IDENTIFY POWER MIRROR CONTROL LINES



IMPORTANT

A few vehicles may have 4 control lines per side mirror, if your vehicle has this setup, that means two of four lines are common and therefore identical in function. Find out which pair of the 4 wires test +12v in exactly the same switch directions (most often they are the same color) and make a special note of their colors. When you proceed to the next step, you will need to combine each pair of common lines and treat them as one.

1. Examine the wiring setup going into the power mirror. There should be a single collection of wires (varying number of wires) connecting each power mirror to the power mirror adjustment switch (the switch that the driver uses to adjust the mirror).
2. For each side mirror, identify the wires that control the power mirror motors using the following procedure:
 - a. Ensure that the wiring harness in the removed interior door panel (which typically contains the mirror adjustment switch) is still connected to the door's corresponding wiring harness.
 - b. Turn the ignition to I (ON) position.
 - c. For each wire in the wire collection leading the power mirror, attach a test light or voltmeter and then press the mirror adjustment switch in the UP, DOWN, LEFT, RIGHT directions.
 - d. If a wire displays +12v when pressing any of the adjustment switch directions, write down its color.
 - e. Repeat this process for all wires in that wiring collection. By the time you're done, you should have identified **3 power mirror control wires for each side mirror**. Make sure you keep tabs of their colors and which side mirror they belong to.

STEP 2

FIGURE 1

TYPICAL OEM POWER MIRROR LAYOUT

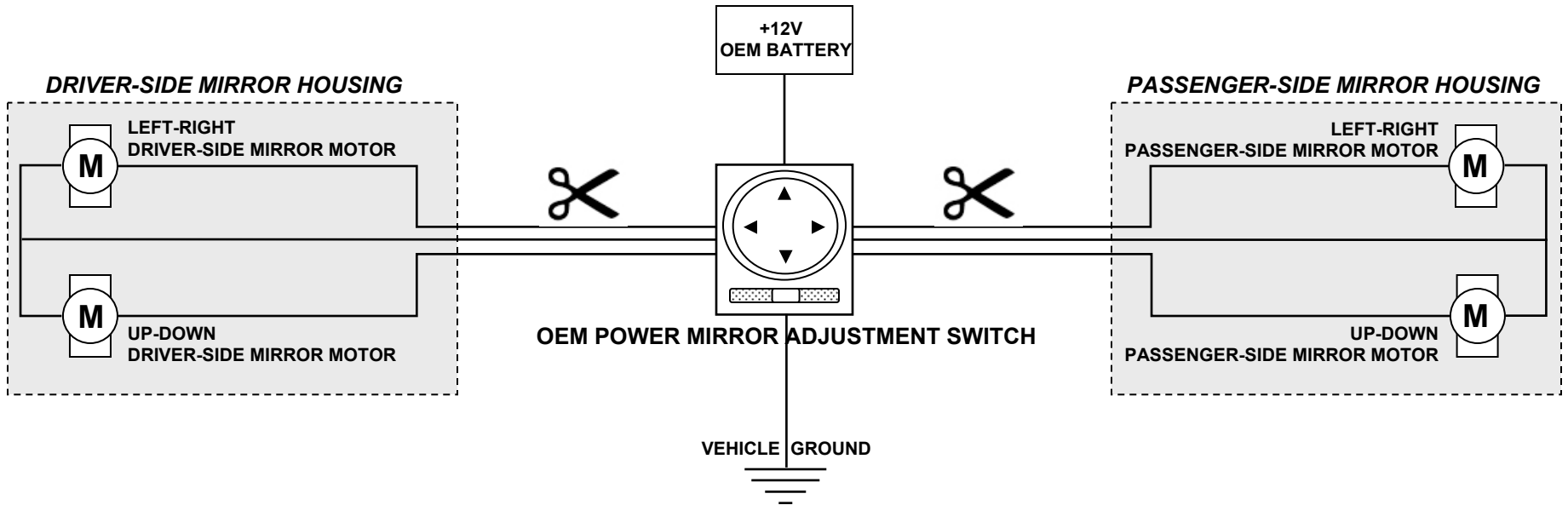

✂ = indicates where the power mirror wires will be cut. Each end of the cut wires will then be rerouted through the LaneFX unit.

REROUTE MIRROR CONTROL LINES THROUGH LANEFX



VERY IMPORTANT

The cuts must be made at the closest point to the mirror motors (ahead of the adjustment switch and any ECU's and other door electronics).

CAUTION

For this step, follow the exact order you used in the above step when you connected the switch lines. (i.e. be sure not to mix and match such that one power mirror wire end is connect to LaneFX as switch line #2 but it's other end is connected to control line #3).

1. In **Figure 1**, the OEM (factory) wiring setup of a typical power mirror setup is shown.
2. For each side mirror, **cut the mirror control lines** between the mirror itself (mirror motors) and the power mirror adjustment switch (the switch that the driver uses to adjust the mirror). When you make the cut, be sure to label each end **as control side** (representing the side connected to the power mirror motors) **and switch side** (representing the wire segment connected to the power mirror adjustment switch).
3. Route the power mirror wires through the LaneFX main unit. The LaneFX unit will act as a "go-between" between the switch and the mirrors. **Make connections exactly according to Figure 2.**
4. First connect the switch lines to the appropriate lines in the LaneFX Molex harness. For this step, you can make these connections in any order (i.e. it doesn't matter which of your three switch lines you designate as LaneFX switch lines #1, #2 or #3).
5. Then, connect the mirror control lines to the appropriate corresponding lines in the LaneFX Molex harness. **Keep the same order as the connections you made with the switch lines.**
6. **Repeat this process for the other side mirror.** Note that LaneFX has a separate wiring harness for the driver-side and passenger-side mirrors. The driver-side Molex has 13 pins/wires. The passenger-side Molex has 10 pins/wires.

STEP 3

FIGURE 2

LANEFX WIRING DIAGRAM

IMPORTANT
All LaneFX wire colors shown are actual & accurate.
Patents Pending. Copyright © 2004-2007 Drivaware Inc.®

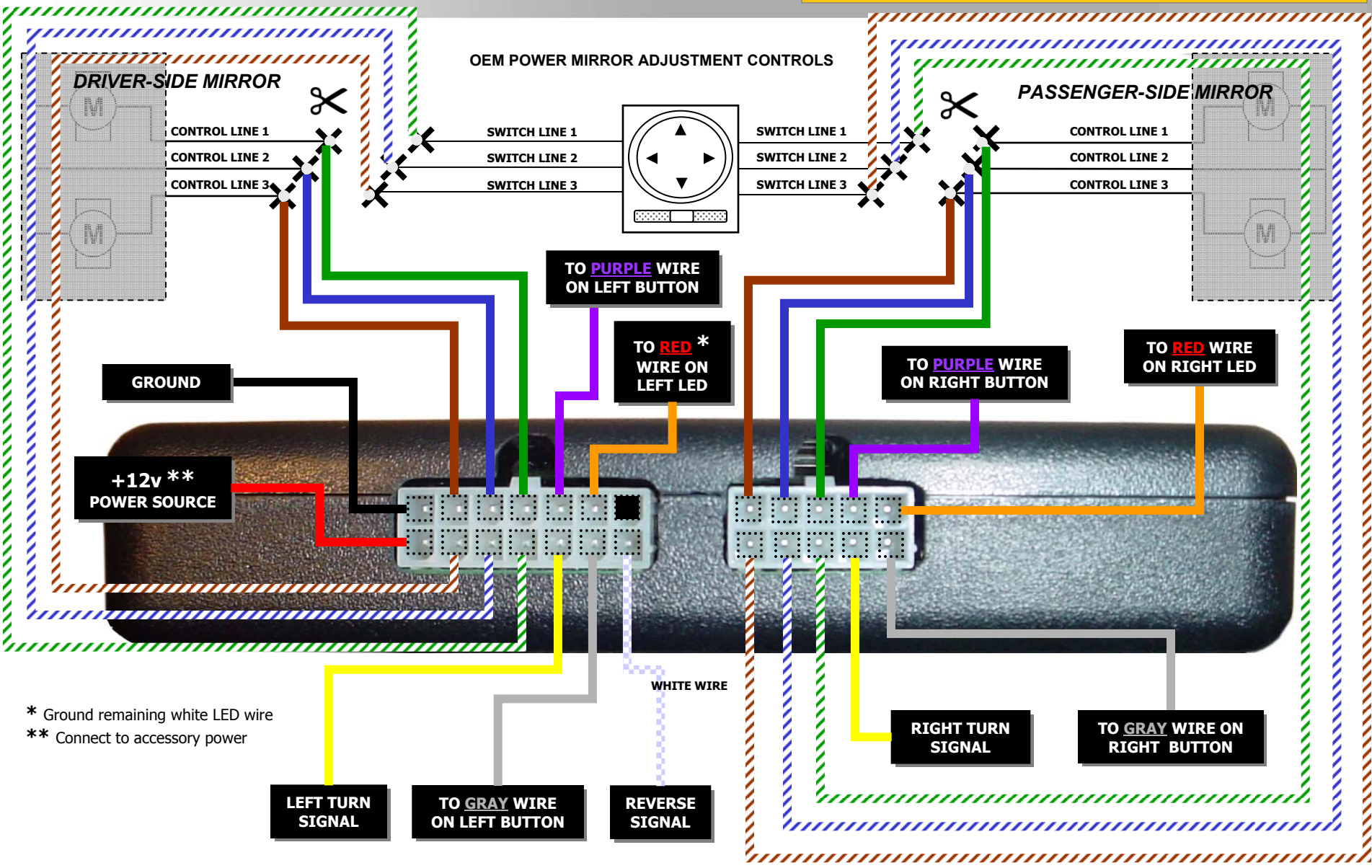

* Ground remaining white LED wire
** Connect to accessory power

MAKE REMAINING CONNECTIONS



IMPORTANT

Follow exact wire colors for LED and button connections

TIP

If your vehicle's electronics are multiplexed (i.e. if you cannot find a unique wire for each of the left turn signal, right turn signal, and reverse light), you will have to make all three of these connections directly from the tail lamps.

TIP

If your vehicle's turn signals have reverse polarity, you should add a relay to each connection to correct the polarity.

- 1. Mount the LaneFX LED indicator and the LaneFX activation buttons inside the vehicle.** Connect these components' wires to the LaneFX wiring harnesses according to the LaneFX wiring diagram in Figure 2. Ensure that the connections for the left and right LEDs and left and right activation buttons are in order. For example, you should not end up with a left activation button that activates the right LED.
- 2. Connect the wires for reverse signal and left & right turn signals** to the LaneFX wiring harness according to the wiring diagram in Figure 2.

STEP 4

COMPLETE & TEST INSTALLATION



TIP

Check the LaneFX main unit with the vehicle turned off. If the unit is powered on, that means you've connected the unit to constant +12v power. Disconnect power, identify accessory (ignition number II position power) +12v power source and redo the connection to power the LaneFX unit.

IMPORTANT

If there is no mirror movement OR the mirror movement is in the wrong direction, you may have to proceed to the next step "Program LaneFX to Learn Vehicle." before you can check for proper mirror movement. At this step no mirror movement is not necessarily due to incorrect wiring. Program the unit and retest.

1. Connect the ground wire. Then, connect +12v power as shown in the LaneFX wiring diagram in Figure 2.
2. Clean up wiring and general installation, but do not replace any of the removed interior panels yet.
3. Start the vehicle.
4. Check that the LaneFX main unit is starting up / receiving power.
5. **Program the system (using Learn Mode described in next step).**
6. Use the vehicle's power mirror adjustment controls in various directions to **test that LaneFX is now controlling each mirror.**
7. Test the button and LED connections. Press each LaneFX activation button and ensure that some LaneFX movement in the corresponding mirror occurs. Also check that the corresponding LED indicator is on for the duration of that mirror movement.
8. If a mirror does not move at all based on pressing the adjustment switch, then go back to **the key "switch" and "control" lines** with a voltmeter or test light and ensure that you have made solid connections behind a) the switch and LaneFX, b) the mirror motors and LaneFX, and most importantly c) all of the extension wiring used in the installation.

STEP 5

PROGRAM LANEFX TO LEARN THE VEHICLE



TIP

See Owners Guide for more information on LaneFX buttons, their location and function.

INFO

Your LaneFX is equipped with **Intelligent Install technology**. It is capable of learning each relevant signal specific to your vehicle. Each function is programmed once at installation and LaneFX remembers it from that point on, even if the vehicle's battery dies or the if the LaneFX unit was removed from the vehicle.

1. From the LaneFX main run screen, press the [+] or [-] button until you reach "ENTER LEARN MODE" screen. Press [ENTER].
2. Use [+] or [-] to scroll between the learn options. Select the vehicle function you would like LaneFX to learn by pressing [ENTER]. Start with: Left LaneFX mirror movement and Right LaneFX mirror movement.
3. For LaneFX mirror movement learn function (perform once for left mirror and again for the right mirror):
 - a. Set the Left-Right selector on the power mirror adjustment switch to the side of the mirror LaneFX is learning.
 - b. When instructed by the LaneFX LCD screen, press and hold the power mirror adjustment switch in the direction shown on LaneFX's LCD screen. Release when instructed.
4. From the LaneFX main run screen, press the [+] or [-] button until you reach "ENTER LEARN MODE" screen. Press [ENTER]. From the learn menu, scroll to the desired learn function, then press [ENTER].
 - a. For Left turn signal learn function: when instructed by the LaneFX LCD screen, activate the left turn signal. Release when instructed.
 - b. For Right turn signal learn function: when instructed by the LaneFX LCD screen, activate the right turn signal. Release when instructed.
 - c. For Reverse signal learn function: Put on parking brake. Keep the brake pedal pressed. When instructed by the LaneFX LCD screen, put the vehicle in reverse. Take the vehicle out of reverse (and into Park in automatic transmission vehicles) when instructed.
5. At the end of each learn sequence, LaneFX will prompt you to save the newly learned information. Press [ENTER] and you should see LaneFX go through a "restart" sequence and then it's ready for normal operation.

STEP 0

CALIBRATE MIRROR RETURN ACCURACY

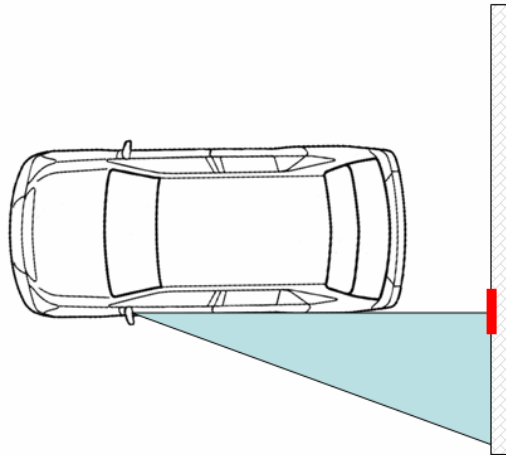

Figure 3

1. Back the vehicle to a wall such that the rear bumper is no more than half of a car length away from the wall, as shown in Figure 3.
2. Affix a laser pointer on the base of the vehicle's side window such that it directs a laser beam onto the mirror surface which in turn reflects back to a point on the wall.
3. When the mirror is in its normal, driver-set position, mark a 1 foot x 1 foot square on the wall (denoted in red in Figure 3), the center of which is the laser dot which reflects the mirror's original position.
4. If the mirror's inaccuracy is in the Left-Right direction, activate LaneFX using the control button repeatedly about 6-12 times. If the mirror inaccuracy is in the Up-Down direction, activate ParkFX by putting the vehicle in and out of reverse. Repeat this step about 6-12 times.
5. If the reflected laser point stays within the marked square on the wall, then no further calibration for that movement is necessary. If the laser point leaves the square, make note of the direction that it is moving away from the square and proceed to calibrate that movement.

STEP 7

CALIBRATE MIRROR RETURN ACCURACY



TIP

Always test mirror return accuracy adjustments by repeating the LaneFX (or ParkFX) movement multiple times. This is the best way to determine if the mirror is returning reliably to its original position or if further adjustments are required.

TIP

Don't forget: LaneFX movements are disabled when you are making adjustments in the system. Save any adjustments and return to the normal run screen before activating LaneFX again.

6. From the normal run screen, use [+] / [-] to get to "ADJ MIRROR RETURN ACCURACY."
7. [+] / [-] to choose which mirror (Left or Right) you would like to make a change.
8. A warning screen will appear, press [ENTER] to continue or [CANCEL] to exit.
9. [+] / [-] to choose which mirror movement direction (Left-Right or Up-Down) to adjust.
- 10. To adjust the Left – Right (LaneFX) mirror movement accuracy:**
 - a. If after repeated LaneFX uses, the mirror is inching in closer to you, then use [-] to decrease the mirror accuracy value.
 - b. If after repeated LaneFX uses, the mirror is widening its view (inching away from you) then use the [+] to increase the mirror accuracy value.
- 11. To adjust the Up – Down (ParkFX) mirror movement accuracy:**
 - a. If after repeated ParkFX uses, the mirror is increasingly pointing lower, then use [+] to increase the mirror accuracy value.
 - b. If after repeated ParkFX uses, the mirror is increasingly pointing higher, then use [-] to decrease the mirror accuracy value.
12. Press [ENTER] to save. System will restart and your new setting is active.
13. Repeat steps 10 or 11 as applicable to test the mirror's accuracy until the laser point stays consistently inside the marked square on the wall.

STEP 7

COMPLETE INSTALLATION

**TIP**

Detailed instructions on how to personalize LaneFX are available in the accompanying LaneFX Owners Guide.

1. Test complete LaneFX setup thoroughly.
2. Replace all removed vehicle interior panels and ensure proper fit.
3. Insert the LaneFX Owners Guide in the vehicle's glove compartment.
4. Personalize your LaneFX. With LaneFX, you can customize:
 - a. how far each mirror moves out,
 - b. how long it pauses,
 - c. how fast it should move
 - d. choose one of two turn signal modes
 - e. how far mirrors should tilt down when the vehicle is backing up
 - f. which mirror should tilt down when the vehicle is backing up

Take some time to test different LaneFX settings until you find the right setup that fits your personal driving style. Customizing LaneFX is very similar to adjusting power seat position when you buy a new car. Sometimes, your very first seat adjustment may not be the perfect fit. So try out different adjustments with your LaneFX system until you find the right comfort zone for your drive.

STEP 8



Toll-free	(866) 4-LANE-FX
Web	support.LaneFX.com
Technical Support	support@LaneFX.com



MADE IN USA

DRIVAWARE REMINDS YOU TO ALWAYS WEAR YOUR SEAT BELT, EXERCISE CAUTION WHEN MERGING OR CHANGING LANES, OBEY ALL TRAFFIC LAWS AND ALWAYS RELY ON YOUR PRIMARY SENSES IN MAKING DRIVING DECISIONS. DRIVAWARE, THE DRIVAWARE MIRROR ICON LOGO, LANEFX AND THE LANEFX SHIELD ARE EITHER TRADEMARKS OR REGISTERED TRADEMARKS OF DRIVAWARE INCORPORATED. PATENTS PENDING. COPYRIGHT © 2005-2007 DRIVAWARE INC. ALL RIGHTS RESERVED.